

DC310
CHIUDIPIORTA AEREO
DOOR CLOSER

DC

FS



FORZA REGOLABILE
ADJUSTABLE CLOSING POWER

PRODOTTO CONFORME ALLA NORMATIVA EN 1154 - EN 1634
CERTIFIED PRODUCT EN 1154 - EN 1634



APPLICAZIONI E MONTAGGIO APPLICATIONS AND MOUNTING

Montaggio su porta lato cerniera (esempio su porta sinistra)
Application on door hinge side (picture: on left hand door)

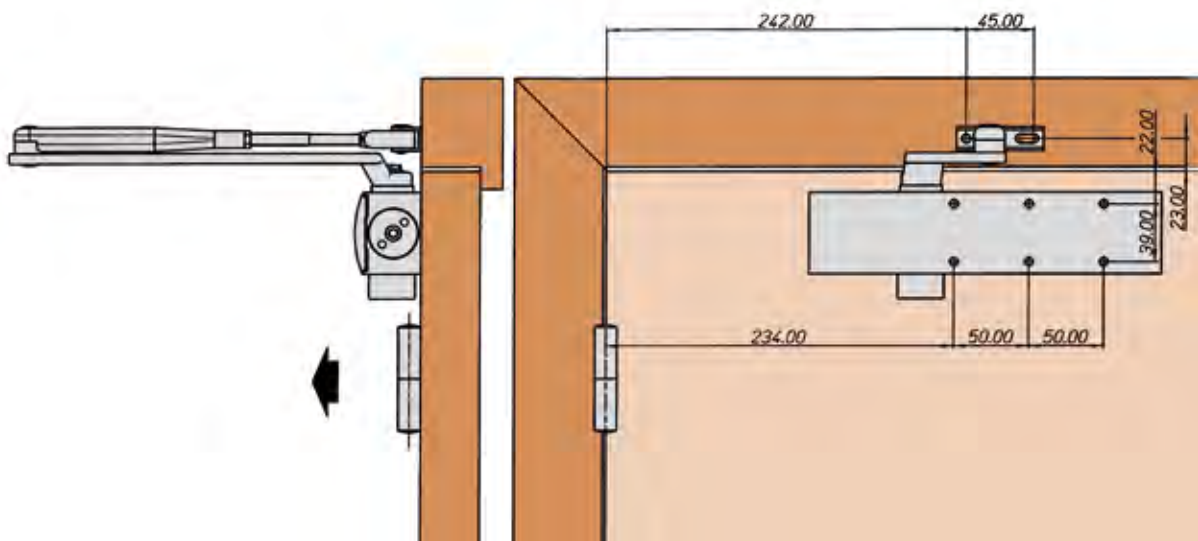

Montaggio su telaio lato opposto cerniera (esempio su porta sinistra)
Application on frame, hinge opposite side (picture: on left hand door)

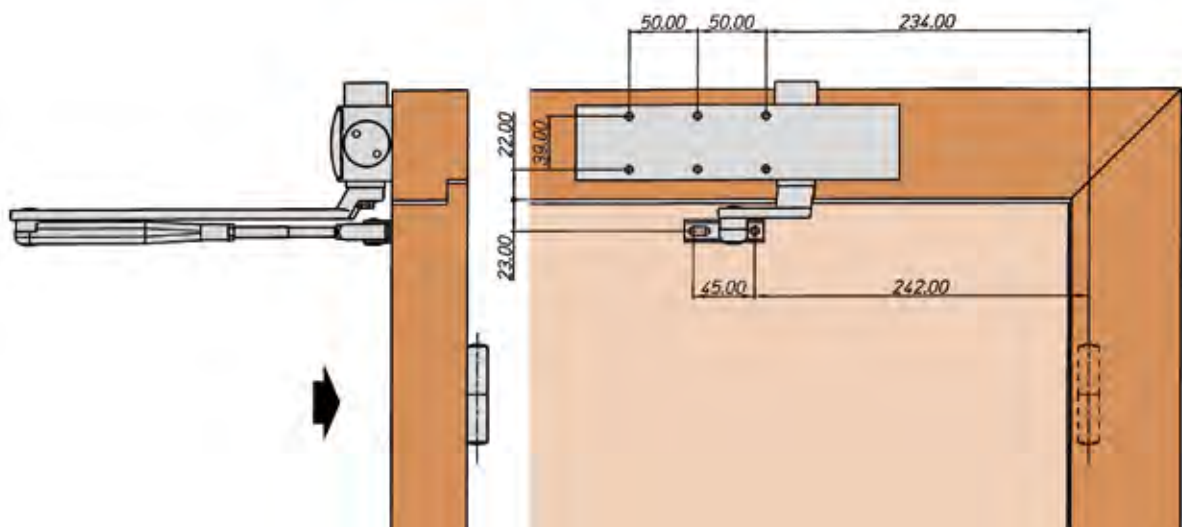

Per il montaggio su porte destre, le dimensioni sono identiche ma speculari
For right hand opening doors, dimensions are identical but symmetrical

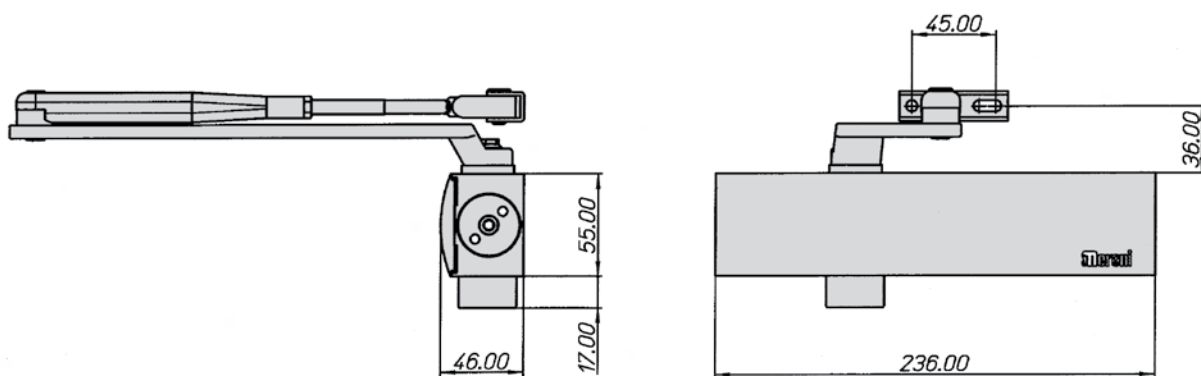

CARATTERISTICHE TECNICHE DC310

TECHNICAL FEATURES DC310

Forza regolabile Regolazione tramite molla	EN 2-3-4-5	Adjustable closing power Power regulation by springs	EN 2-3-4-5
Massima larghezza porta	EN 2 mm 850 EN 3 mm 950 EN 4 mm 1100 EN 5 mm 1250	Maximum door width	EN 2 mm 850 EN 3 mm 950 EN 4 mm 1100 EN 5 mm 1250
Peso porta	EN 2 Kg 25 ÷ 45 EN 3 Kg 45 ÷ 60 EN 4 Kg 60 ÷ 80 EN 5 Kg 80 ÷ 110	Door weight	EN 2 Kg 25 ÷ 45 EN 3 Kg 45 ÷ 60 EN 4 Kg 60 ÷ 80 EN 5 Kg 80 ÷ 110
Esecuzione per porta	DIN destro DIN sinistro	Non - Handed	DIN right DIN left
Velocità di chiusura e colpo finale regolabili da 2 valvole indipendenti	180° - 10° 10° - 0°	Adjustable closing and final latch speed by means of 2 independent valves	180° - 10° 10° - 0°
Braccio	ST standard HO con fermo HS a slitta con fermo	Arm	ST standard HO hold open HS sliding arm hold open
Finiture standard	NA verniciato argento NE verniciato nero	Standard finishes	NA enamelled silver NE enamelled black
Altre finiture	A richiesta	Other finishes	On demand
Dimensioni	Lunghezza mm 236 Larghezza mm 55 Altezza mm 46	Dimensions	Length mm 236 Width mm 55 Height mm 46
Confezione	Scatola da 1 pz	Packaging	Box in 1's
Peso (incluso confezione)	Kg 2,30	Weight (box included)	Kg 2,30

Fornito con:

1 braccio (da specificare)
1 coperchietto
6 viti di fissaggio per legno
6 viti di fissaggio per metallo

Supplied with:

1 arm (to be advised)
1 cover
6 fixing screws for wood
6 fixing screws for metal

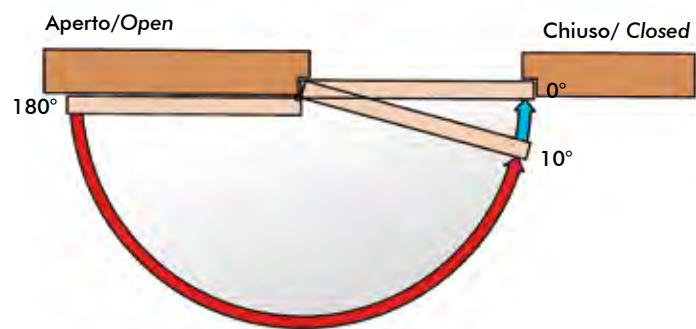
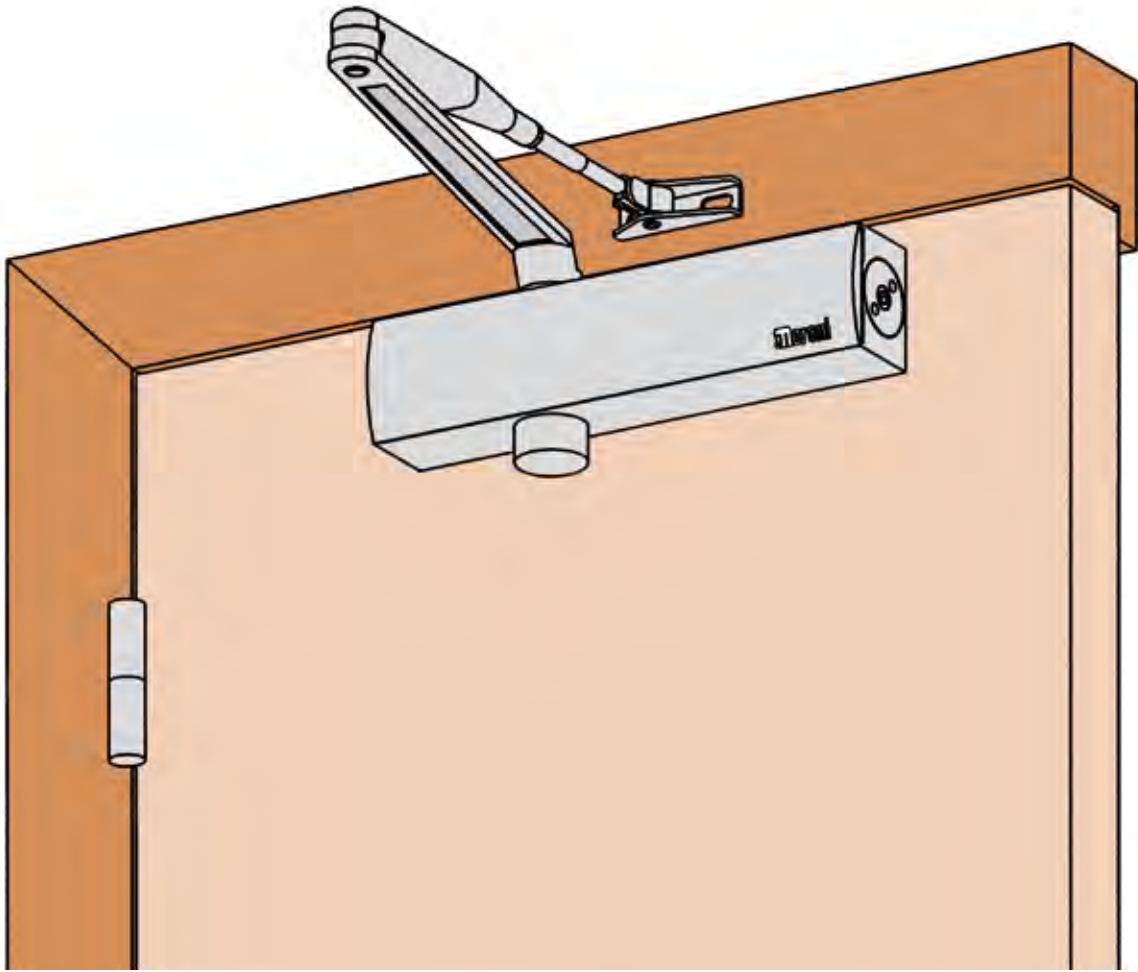

 Velocità di chiusura/Closing speed

 Velocità del colpo finale/Final latch

ACCESSORI PER CHIUDIORTA AEREI DOORS CLOSER ACCESSORIES



Braccio standard per art. 110 - 150
Standard arm for item 110 - 150



Braccio con fermo per art. 110 - 150
Hold open arm for item 110 - 150



Braccio standard per art. 210 - 310
Standard arm for item 210 - 310



Braccio con fermo per art. 210 - 310
Hold open arm for item 210 - 310



Copertura per art. 110 / Finiture su richiesta
Cover for item 110 / Finishes on demand



Braccio a slitta con fermo rimovibile
per art.110-150-160-210-310

Sliding arm with removable hold open
for item 110-150-160-210-310

ATTENZIONE: l'utilizzo del braccio a slitta comporta una diminuzione di forza pari a 1 grado.

ATTENTION: the use of a sliding arm results in a 1 degree power reduction.

DC

FS

ACCESSORI PER CHIUDIORTA AEREI

DOORS CLOSER ACCESSORIES

TABELLA DIMENSIONI DI MONTAGGIO BRACCIO A SLITTA

SLIDING ARM INSTALLATION DIMENSIONS

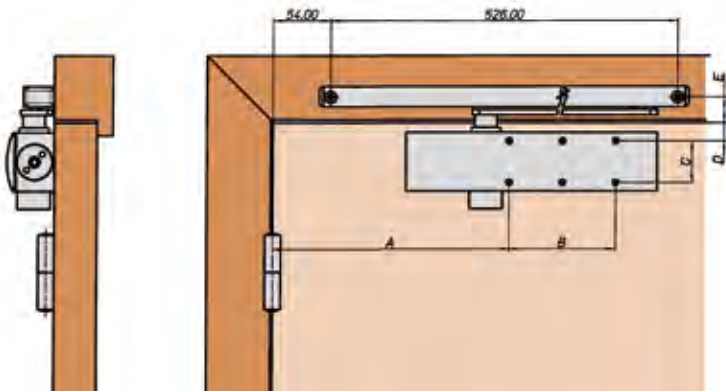

Montaggio su porta lato cerniera Door leaf fixing (pull side)					
	DC110	DC150	DC160	DC210	DC310
A	117,5	118	127	222	222
B	165	203	280	100	100
C	19	19	19	39	39
D	21	24	23	17	17
E	26	26	27	24	24

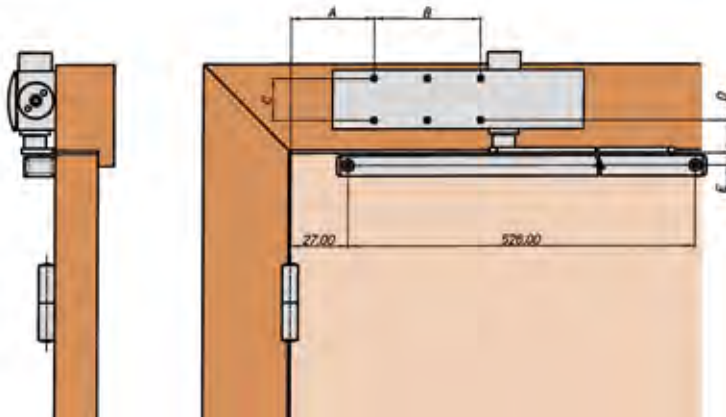

Montaggio su telaio Frame fixing (pull side)					
	DC110	DC150	DC160	DC210	DC310
A	117,5	79,2	33	78	78
B	165	203	280	100	100
C	19	19	19	39	39
D	37	40	40	32	32
E	10	10	10	10	10

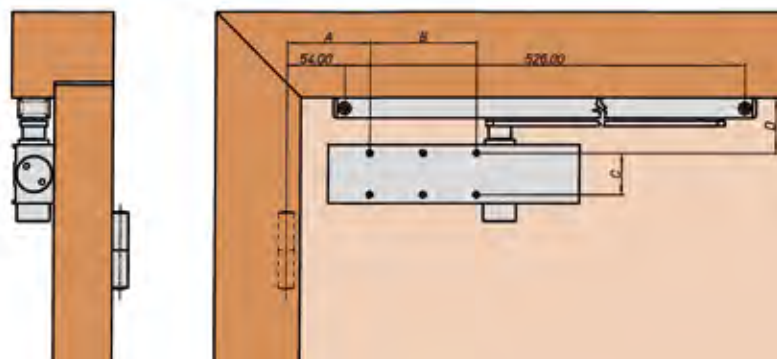

Montaggio su porta lato opposto cerniera/braccio parallelo Door leaf fixing push side/parallel arm					
	DC110	DC150	DC160	DC210	DC310
A	117,5	79,2	33	78	78
B	165	203	280	100	100
C	19	19	19	39	39
D	57	60	60	52	52